

The RC Time Constant

OBJECTIVES

- Investigate the time needed to discharge a capacitor in an RC circuit.
- Measure the voltage across a resistor as a function of time in an RC circuit as a means to determine the RC time constant.
- Determine the value of an unknown capacitor and resistor from the measurements.

EQUIPMENT LIST

- Voltmeter (at least 10 M Ω resistance-digital readout), laboratory timer
- Direct current power supply (20 V), high quality unknown capacitor (5–10 μ F)
- Unknown resistor (approximately 10 M Ω), single-pole (double-throw) switch
- Assorted connecting leads

THEORY

Consider the circuit shown in Figure 33-1 consisting of a capacitor C , a resistor R , a source of emf ϵ , and a switch S . If the switch S is thrown to point A at time $t = 0$ when the capacitor is initially uncharged, charge begins to flow in the series circuit consisting of ϵ , R , and C , and it flows until the capacitor is fully charged. The current I has an initial value of ϵ/R and decreases exponentially with time. The charge Q on the capacitor begins at zero and increases exponentially with time until it becomes equal to $C\epsilon$. The equations that describe those events are

$$Q = C\epsilon(1 - e^{-t/RC}) \quad \text{and} \quad I = \epsilon/R e^{-t/RC} \quad (\text{Eq. 1})$$

The quantity RC is called the **time constant** of the circuit, and it has units of seconds if R is in ohms and C is in farads. After a period of time that is long compared to the time constant RC , the charge Q is equal to $C\epsilon$, and the current in the circuit is zero.

If switch S is now thrown to position B , the capacitor discharges through the resistor. The charge on the capacitor and the current in the circuit both decay exponentially while the capacitor is discharging. The equations that describe the discharging process are

$$Q = C\epsilon e^{-t/RC} \quad \text{and} \quad I = \epsilon/R e^{-t/RC} \quad (\text{Eq. 2})$$

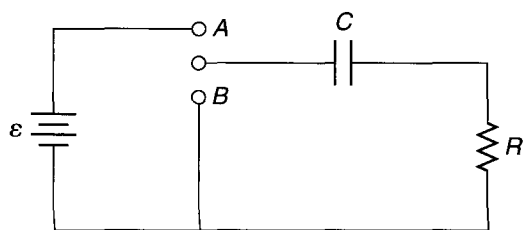

Figure 33-1 Simple series RC circuit.

The current in the discharging case will be in the opposite direction from the current in the charging case, but the magnitude of the current is the same in both cases.

Consider the circuit shown in Figure 33-2 consisting of a power supply of emf ε , a capacitor C , a switch S , and a voltmeter with an input resistance of R . If initially the switch S is closed, the capacitor is charged almost immediately to ε , the voltage of the power supply. When the switch is opened, the capacitor discharges through the resistance of the meter R with a time constant given by RC . With the switch open, the only elements in the circuit are the capacitor C and the voltmeter resistance R , and thus the voltage across the capacitor is equal to the voltage across the voltmeter. It is given by

$$V = \varepsilon e^{-t/RC} \quad (\text{Eq. 3})$$

Rearranging and taking the natural log of both sides of the equation gives

$$\ln(\varepsilon/V) = (1/RC)t \quad (\text{Eq. 4})$$

If the voltage across the capacitor is determined as a function of time, a graph of $\ln(\varepsilon/V)$ versus t will give a straight line with a slope of $(1/RC)$. Thus RC can be determined, and if R the voltmeter resistance is known, then C can be determined.

If an unknown resistor is placed in parallel with the voltmeter, it produces a circuit like that shown in Figure 33-3. The capacitor can again be charged and then discharged, but now the time constant will be equal to $R_t C$ where R_t is the parallel combination of R and R_U . If the relationship between R , R_U , and R_t is solved for R_U , the result is

$$R_U = \frac{RR_t}{R - R_t} \quad (\text{Eq. 5})$$

Therefore, a measurement of the capacitor voltage as a function of time will produce a dependence like that given by Equation 4, except that the slope of the straight line will be $(1/R_t C)$. Thus if C is known and $R_t C$ is found from the slope, then R_t can be determined. Using Equation 5, R_U can be found from R and R_t .

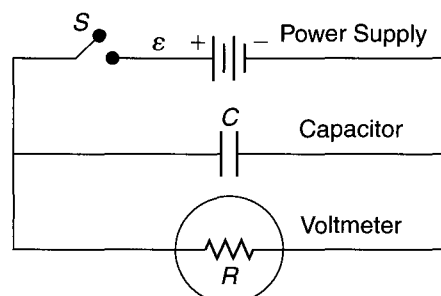

Figure 33-2 An RC circuit using a voltmeter as the resistance.

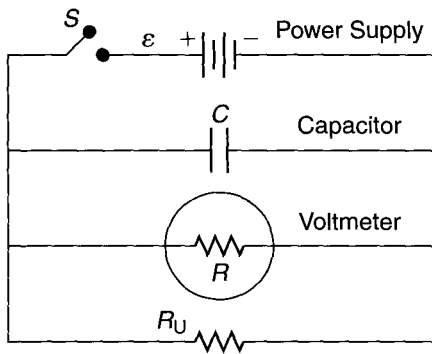

Figure 33-3 RC circuit using voltmeter and R_U in parallel.

EXPERIMENTAL PROCEDURE

Unknown Capacitance

1. Construct a circuit such as the one in Figure 33-2 using the capacitor supplied, the voltmeter, and the power supply. Have the circuit approved by your instructor before turning on any power. Obtain from your instructor the value of the input resistance of the voltmeter and record it in Data and Calculations Table 1 as R .
2. Close the switch, and adjust the power supply emf ε as read on the voltmeter to the value chosen by your instructor. Record the value of ε in Data and Calculations Table 1.
3. Open the switch and simultaneously start the timer.
4. The voltmeter reading will fall as the capacitor discharges. Let the timer run continuously, and for eight predetermined values of the voltage, record the time t at which the voltmeter reads these voltages. A convenient choice for voltages at which to measure t would be increments of 10%. For example, if $\varepsilon = 20.0$ V, then use voltage of 18.0, 16.0, 14.0, etc. Record the voltage V and times t in Data and Calculations Table 1.
5. Repeat Steps 2 through 4 two more times for Trials 2 and 3.

Unknown Resistance

1. Construct a circuit such as the one in Figure 33-3 using the same capacitor used in the last circuit and the unknown resistor supplied. Close the switch and adjust the power supply voltage to the same value used in the last procedure.
2. Repeat Steps 2 through 5 of the procedure above, and record all values in the appropriate places in Data and Calculations Table 2.

CALCULATIONS

Unknown Capacitance

1. Calculate the values of $\ln(\varepsilon/V)$ and record them in Data and Calculations Table 1.
2. Calculate the mean \bar{t} and the standard error α_t for the three trials of t at each voltage and record them in Data and Calculations Table 1.
3. Perform a linear least squares fit of the data with $\ln(\varepsilon/V)$ as the vertical axis and \bar{t} as the horizontal axis.
4. Record the value of the slope in Data and Calculations Table 1.

5. Calculate RC as the reciprocal of the slope. Record the value of RC in Data and Calculations Table 1.
6. Use the value of RC and the value of R to calculate the value of the unknown capacitor C and record it in Data and Calculations Table 1.

Unknown Resistance

1. Calculate the values of $\ln(\varepsilon/V)$ and record the values in Data and Calculations Table 2.
2. Calculate the mean \bar{t} and the standard error α_t for the three trials of t at each voltage and record them in Data and Calculations Table 2.
3. Perform a linear least squares fit of the data with $\ln(\varepsilon/V)$ as the vertical axis and \bar{t} as the horizontal axis.
4. Record the value of the slope in Data and Calculations Table 2.
5. Calculate the value of $R_t C$ as the reciprocal of the slope. Record the value of $R_t C$ in Data and Calculations Table 2.
6. Using the value of the capacitance C determined in the first procedure and the value of $R_t C$, calculate the value of R_t and record it in Data and Calculations Table 2.
7. Calculate the value of the unknown resistance R_U from the values of R_t and R . Record the value of R_U in Data and Calculations Table 2.

GRAPHS

1. For the data from Data and Calculations Table 1 graph the quantity $\ln(\varepsilon/V)$ as the vertical axis and \bar{t} as the horizontal axis. Also show on the graph the straight line obtained from the linear least squares fit to the data.
2. For the data from Data and Calculations Table 2, graph the quantity $\ln(\varepsilon/V)$ as the vertical axis and \bar{t} as the horizontal axis. Also show on the graph the straight line obtained from the linear least squares fit to the data.

LABORATORY 33 *The RC Time Constant*

PRE-LABORATORY ASSIGNMENT

1. In a circuit such as the one in Figure 33-1 with the capacitor initially uncharged, the switch S is thrown to position A at $t = 0$. The charge on the capacitor (a) is initially zero and finally $C\varepsilon$ (b) is constant at a value of $C\varepsilon$ (c) is initially $C\varepsilon$ and finally zero (d) is always less than ε/R .
2. In a circuit such as the one in Figure 33-1 with the capacitor initially uncharged, the switch S is thrown to position A at $t = 0$. The current in the circuit is (a) initially zero and finally ε/R (b) constant at a value of ε/R (c) equal to $C\varepsilon$ (d) initially ε/R and finally zero.
3. In a circuit such as the one in Figure 33-2 the switch S is first closed to charge the capacitor, and then it is opened at $t = 0$. The expression $V = \varepsilon e^{-t/RC}$ gives the value of (a) the voltage on the capacitor but not the voltmeter (b) the voltage on the voltmeter but not the capacitor (c) both the voltage on the capacitor and the voltage on the voltmeter, which are the same (d) the charge on the capacitor.
4. For a circuit such as the one in Figure 33-1, what are the equations for the charge Q and the current I as functions of time when the capacitor is charging?

$$Q = \text{_____} \quad I = \text{_____}$$

5. For a circuit such as the one in Figure 33-1, what are the equations for the charge Q and the current I as functions of time when the capacitor is discharging?

$$Q = \text{_____} \quad I = \text{_____}$$

6. If a $5.00 \mu\text{F}$ capacitor and a $3.50 \text{ M}\Omega$ resistor form a series RC circuit, what is the RC time constant? Give proper units for RC and show your work.

$$RC = \text{_____}$$

7. Assume that a $10.0 \mu\text{F}$ capacitor, a battery of emf $\varepsilon = 12.0 \text{ V}$, and a voltmeter of $10.0 \text{ M}\Omega$ input impedance are used in a circuit such as that in Figure 33-2. The switch S is first closed, and then the switch is opened. What is the reading on the voltmeter 35.0 s after the switch is opened? Show your work.

$$V = \text{_____ V}$$

8. Assume that a circuit is constructed such as the one shown in Figure 33-3 with a capacitor of $5.00 \mu\text{F}$, a battery of 24.0 V , a voltmeter of input impedance $12.0 \text{ M}\Omega$, and a resistor $R_U = 10.0 \text{ M}\Omega$. If the switch is first closed and then opened, what is the voltmeter reading 25.0 s after the switch is opened? Show your work.

$$V = \text{_____ V}$$

9. In the measurement of the voltage as a function of time performed in this laboratory, the voltage is measured at fixed time intervals. (a) true (b) false

Lab Partners

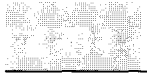
LABORATORY 33 *The RC Time Constant*
LABORATORY REPORT
Data and Calculations Table 1

V (V)	t_1 (s)	t_2 (s)	t_3 (s)	$\ln(\varepsilon/V)$	\bar{t} (s)	α_t (s)
$\varepsilon =$	V	$R =$	Ω	$r =$	Intercept =	
Slope =	s^{-1}	$RC =$	s	$C =$	F	

Data and Calculations Table 2

V (V)	t_1 (s)	t_2 (s)	t_3 (s)	$\ln(\varepsilon/V)$	\bar{t} (s)	α_t (s)
$\varepsilon =$	V	$R =$	Ω	$r =$	Intercept =	
Slope =	s^{-1}	$R_t C =$	s	$R_t =$	Ω	$R_U =$

SAMPLE CALCULATIONS

- $\ln(\varepsilon/V) =$
- $RC = 1/\text{slope} =$
- $C = RC/R =$
- $R_t = R_t C / C =$
- $R_U = (R_t R) / (R - R_t) =$

QUESTIONS

- Evaluate the linearity of each of the graphs. Do they confirm the linear dependence between the variables that is predicted by the theory?
- Ask your instructor for the values of the unknown capacitor and resistor. Calculate the percent error of your measurement compared to the values provided. On this basis, evaluate the accuracy of your measurement of the capacitance and resistance.

