

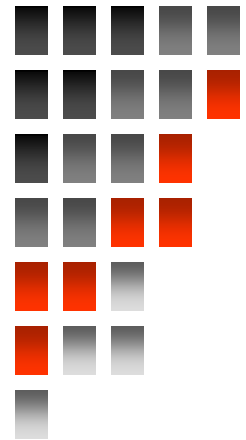

Postal Rate Case & Mailpiece Quality



Presented by: The US Postal Service

June 2007

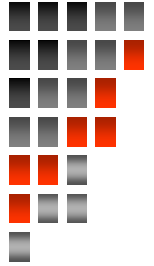

Shaping a More Efficient Future

New Postal Rate Case – Effective May 14, 2007:

- Forever Stamp
- Shape Based Pricing
- Price Changes
- New Processing Categories

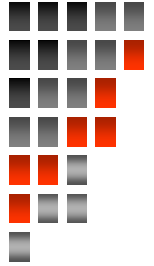

What am I mailing?

- **Mailable**
 - Is your piece mailable?
- **Machinable**
 - Can your piece be processed through USPS automated equipment?
- **Automatable**
 - Is your piece barcoded and automation compatible?
- **New Rate Case Effects**
 - How does the Rate Case Effect what I want to mail?

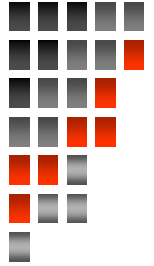

Agenda

Rate Case

- Forever Stamp
- Postal Changes

Classes of Mail

- First-class Mail
- Standard Mail
- Periodicals

Mail Processing Categories

- Postcard
- Letter
- Flat
- Parcel

Mailpiece Characteristics

- Dimensions
- Aspect Ratio
- Plastic Covering
- Odd-Shaped Items
- Flexibility
- Paper Stock
- Reflectance
- Print Contrast

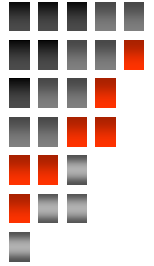

Shaping a More Efficient Future

First-Class Mail[®]

Forever Stamp

- Booklets and sheetlets
- Available April 12
- Single-piece rate 41¢
- Good forever





Shaping a More Efficient Future

First-Class Mail®

New Rate Case – Shape Matters

<u>May 14th:</u>	<u>Before</u>	<u>After</u>
2 oz Letter	63¢	▶ 58¢
2 oz Flat	63¢	▶ 97¢
2 oz Package	63¢	▶ \$1.30



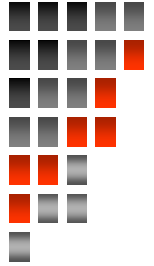

Shaping a More Efficient Future

First-Class Mail[®]

New Pricing – Single-Piece

- Letters 41¢
 - Nonmachinable surcharge 17¢
- Postcards 26¢
- Flats 80¢
- Parcels \$1.13



**** Additional ounce 17¢ - all categories of mail**

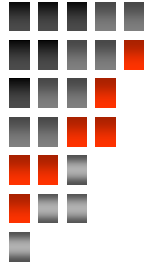

Shaping a More Efficient Future

First-Class Mail®

New Prices – Lower Prices

- Lower prices for
 - Letters over 1 ounce
 - Flats over 6 ounces



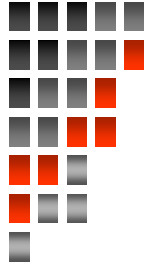

Shaping a More Efficient Future

First-Class Mail[®]

Shape Matters – Example

- Flat-size to letter-size envelope



Save 39¢

2-ounce example



Shaping a More Efficient Future

First-Class Mail[®]

Shape Matters – Example

- Parcel to flat

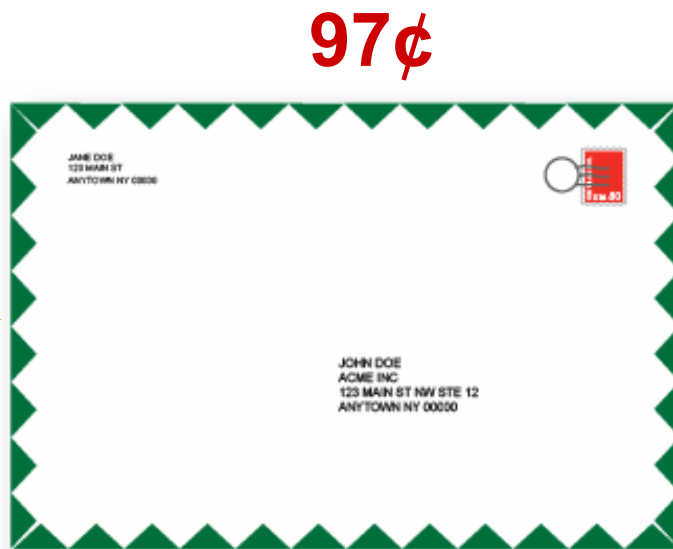

Save 33¢

2-ounce example

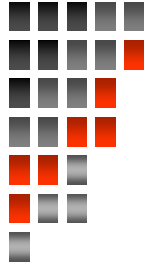

Shaping a More Efficient Future

Standard Mail[®]

Initiatives – bulk mailings

- Greater recognition of shape
- Eliminate DDU rate for letters
- Drop-ship closer to destination

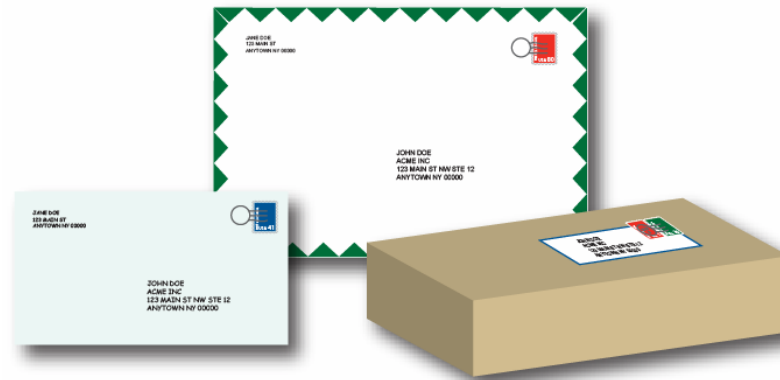

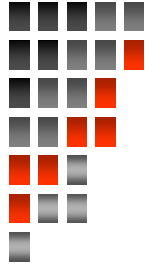

Shaping a More Efficient Future

Standard Mail[®]

New Rate Category – NFM
Non-flat Machinable

- Rigid pieces
- UFSM 1000 standards
- Provides and additional option



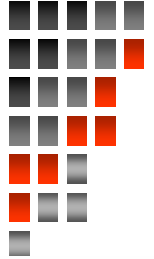

- Where does it all start?
- Understanding the new changes and how it will effect what you mail...



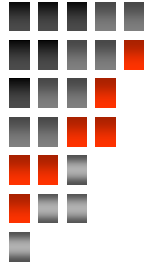

Classes of Mail

● **First-class Mail**

- 1-3 day delivery time
- Mail forwarded or returned to sender at no additional charge
- Ancillary service endorsements available
- Single piece or quantity discounts/500 pieces or more
- Bills, statements or handwritten and/or personal correspondence
- Closed against inspection

● **Standard Mail**

- 7-10 day delivery time
- If undeliverable mail can be disposed of by USPS.
- Ancillary service endorsements available
- Single piece not available – must mail 200 pieces or more
- Printed Matter, circulars, pamphlets, catalogs, newsletters, direct mail & merchandise
- Can be opened and inspected by USPS
- Non-profit mail

● **Periodicals**

- Subscriptions – magazines, newspapers, etc.

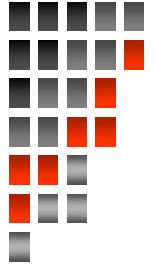

Presort vs Automation

- **Presort**
 - No Barcode
 - Discounted
- **Automation**
 - Barcode
 - Deepest discounts

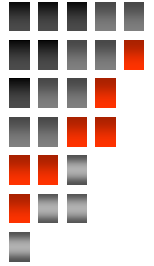

Mail Processing Categories

- **Postcard**

- First-class mail only

- **Letter**

- First-class mail
- Standard mail

- **Flat**

- First-class mail
- Standard mail

- **Parcel**

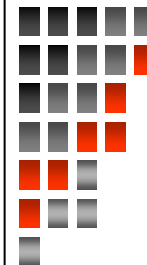

Mailpiece Quality - Postcard Dimensions

- First-Class Postcard Rate

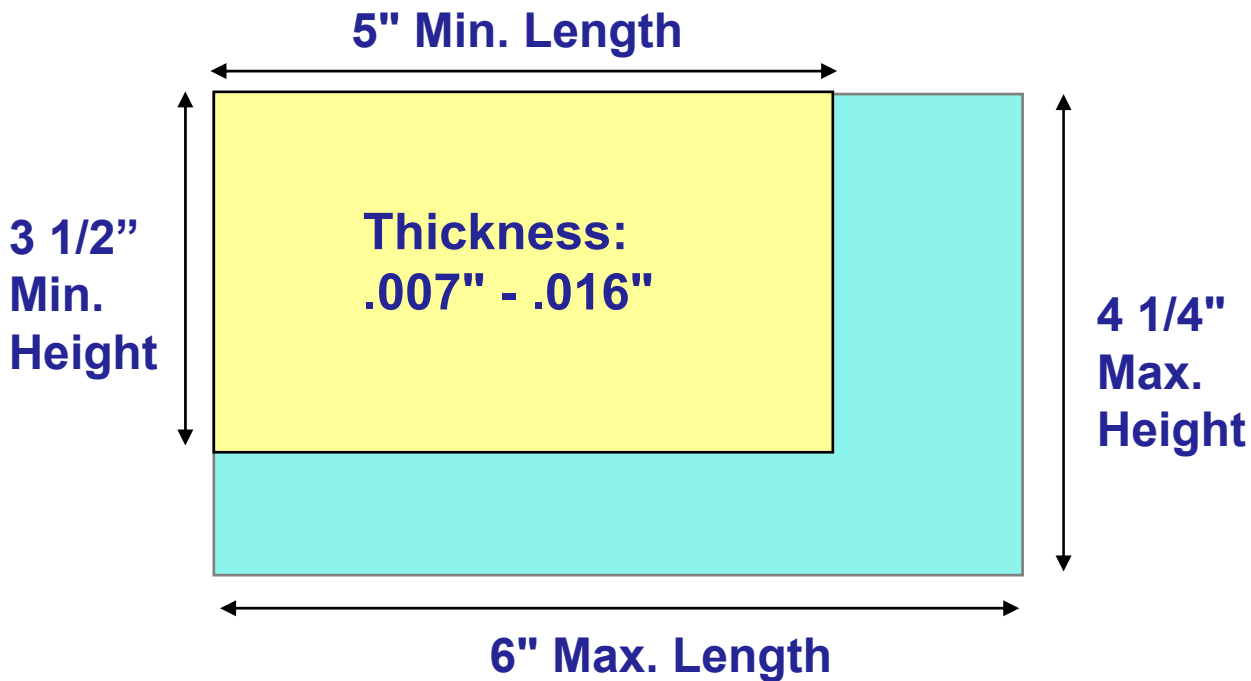

	<u>Minimum</u>	<u>Maximum</u>	<u>First-Class Mail</u> <u>Price</u>
Length	5 inches	6 inches	
Height	3-1/2 inches	4-1/4 inches	
Thickness	0.007 inch	0.016 inch	\$0.26



Mailpiece Quality - Letter-size Dimensions

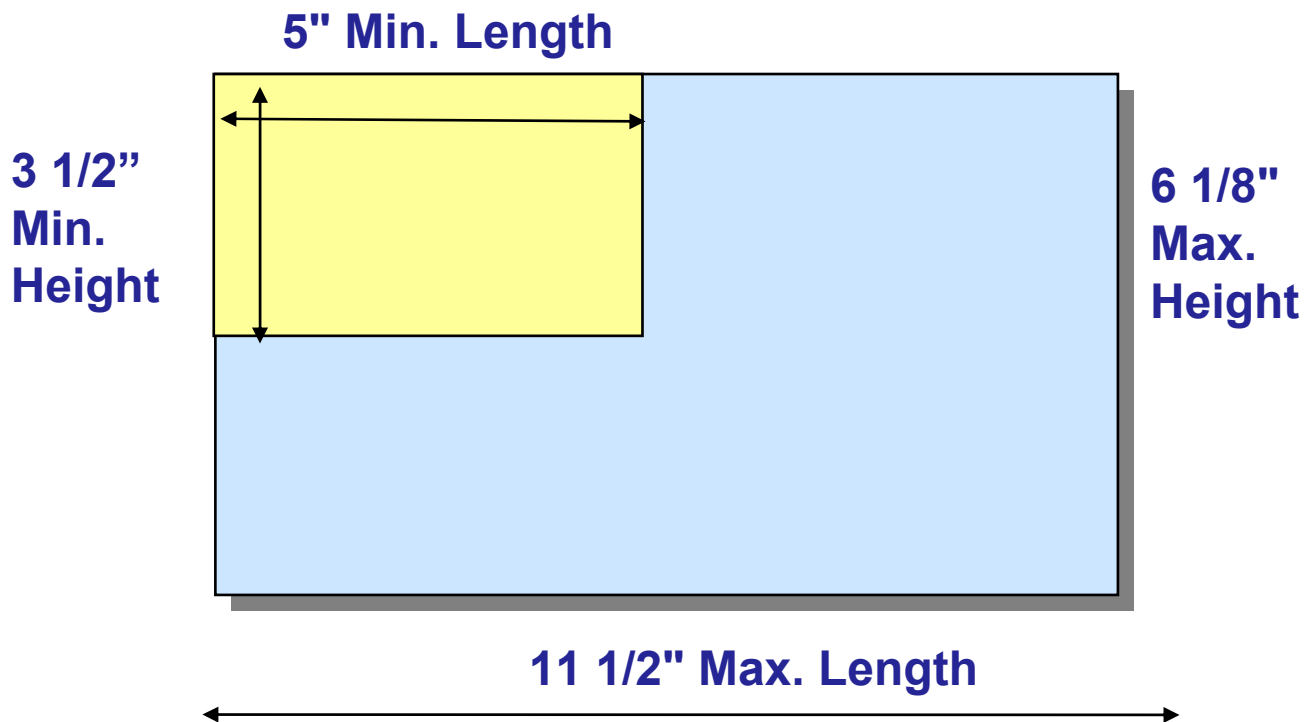

	Minimum	Maximum	Weight not over (ounces)	First-Class Mail Price
Length	5 inches	11-1/2 inches	1	\$0.41
Height	3-1/2 inches	6-1/8 inches	2	\$0.58
Thickness	0.007 inch	1/4 inch	3	\$0.75
			3.5	\$0.92

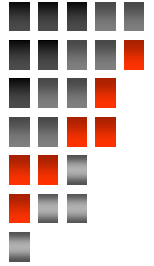

Mailpiece Quality - Letters Thickness

- **Pieces exceeding 4 1/4" X 6" and less than .009" thick cannot be mailed**

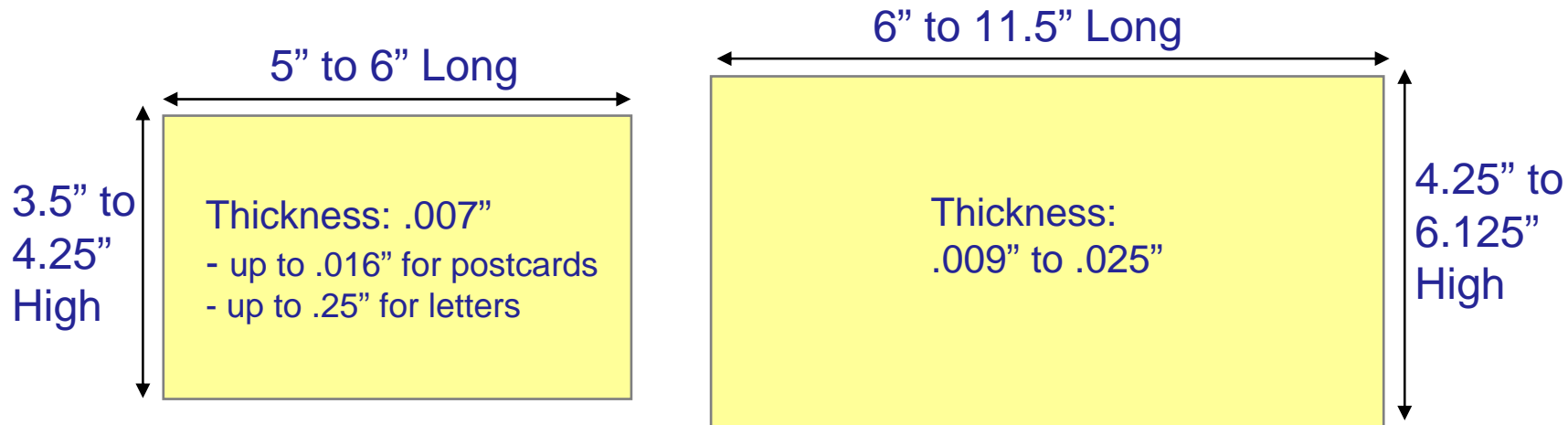

- **Automation letter rate pieces must meet the above dimensions**

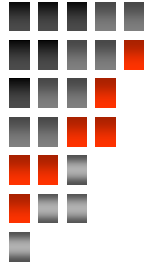

Pricing by Shape

Did You Know?

If a letter exceeds any of the maximum dimensions or weighs more than 3.5 ounces, it is priced as the next shape price category. Example: a letter exceeding $\frac{1}{4}$ inch thickness would be priced as a large envelope.

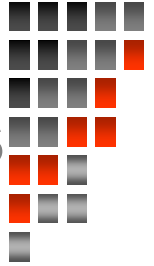

Mailpiece Quality - Flat-size Dimensions

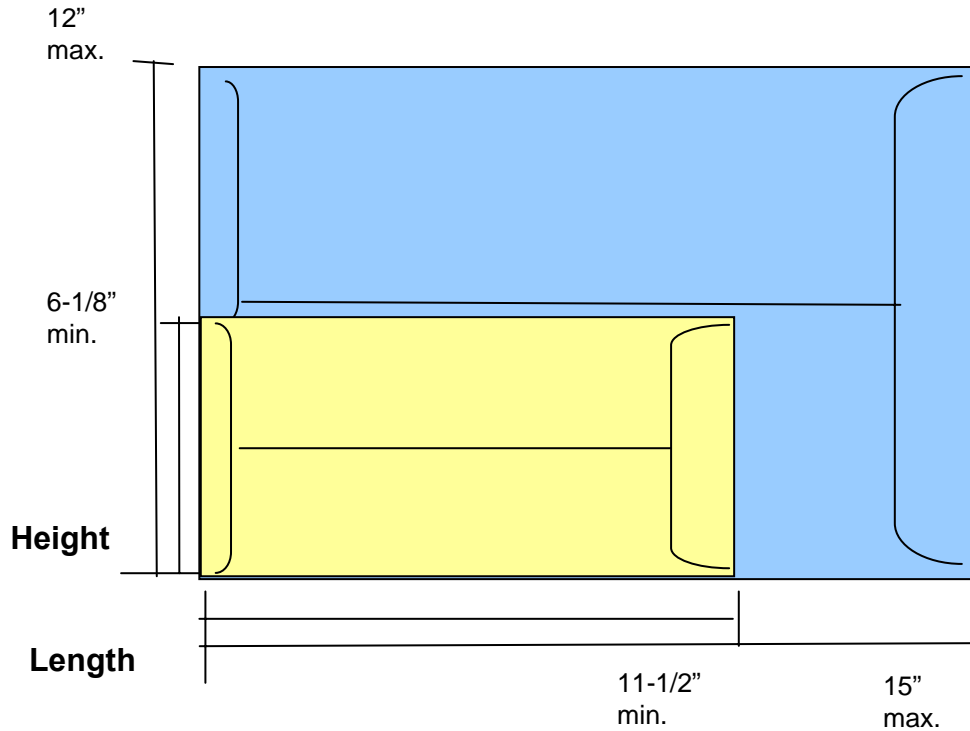

Minimum* Maximum

Length 11-1/2" 15 "

Height 6-1/8 " 12 "

Thickness 1/4 inch 3/4 inch

**Weight not
over
(ounces)**

- 1
- 2
- 3
- 4
- 5
- 6
- 7
- 8
- 9
- 10
- 11
- 12
- 13

**First-Class
Mail Price**

- \$0.80
- 0.97
- 1.14
- 1.31
- 1.48
- 1.65
- 1.82
- 1.99
- 2.16
- 2.33
- 2.50
- 2.67
- 2.84

*Flats exceed at least one of these dimensions

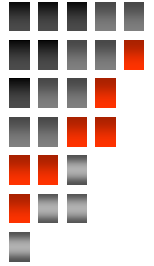

Mailpiece Quality – Parcel Dimensions

FIRST-CLASS PACKAGES

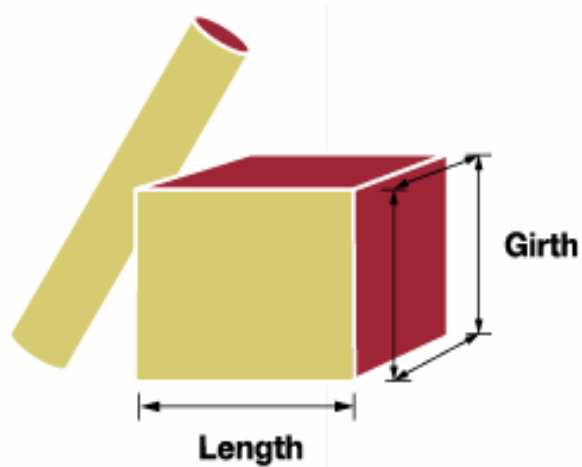

SIZE	PROPOSED PRICE	
	Weight not over (ounces)	Price
Length + Girth		
Length + girth cannot exceed 108 inches.		
	1	\$1.13
	2	1.30
	3	1.47
	4	1.64
	5	1.81
	6	1.98
	7	2.15
	8	2.32
	9	2.49
	10	2.66
	11	2.83
	12	3.00
	13	3.17

Length

The longest side of the parcel

Girth

Measurement around the thickest point



New Shape Based Rate Case

Shape Matters:

First Class Mail

Before

After May 14

2 oz Letter

63¢



58¢

2 oz Flat

63¢



97¢

2 oz Package

63¢



\$1.30

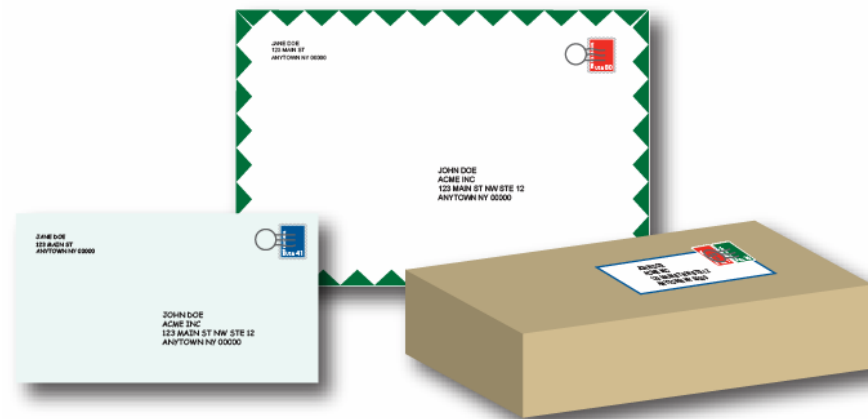

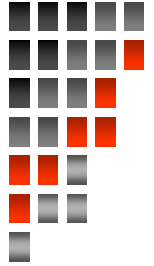

Postcard Notes:

- First-Class postcards exceeding postcard dimensions are eligible for First-Class Mail letter rates.
- Standard Mail has no postcard rate and qualify for the appropriate Standard Mail letter rate.



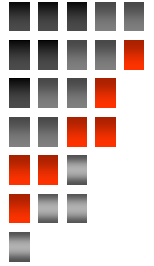

Self-folded Mailers

Tabs
Wafer Seals
Spot Glue

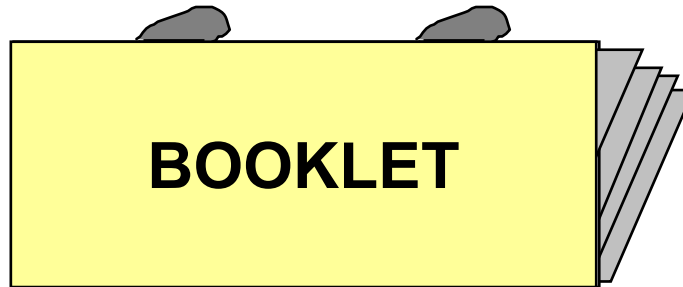

BOOKLET

20 lbs.

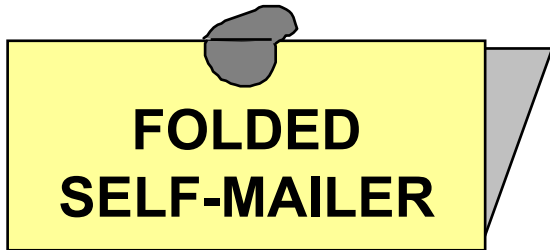

**FOLDED
SELF-MAILER**

**Single Sheet
28 lbs.**

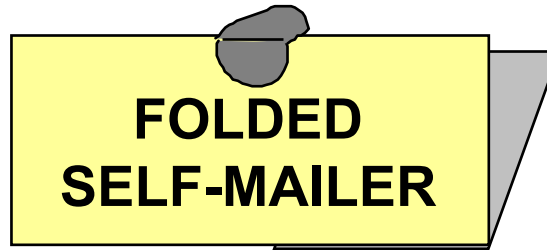

**FOLDED
SELF-MAILER**

**Multiple Sheets
24 lbs.**

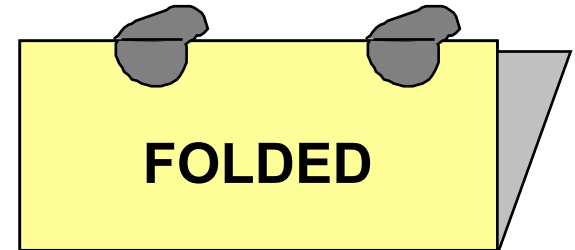

FOLDED

**Single/Multiple Sheets
20 lbs.**

Is the fold on top? If so, two tabs are required on the bottom (1" in from either side).

When saddle stitched, spine MUST be on the bottom.

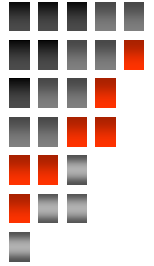

Non-machinable Surcharges

Examples of Letter Nonmachinability:

**Rigid or contains odd-shaped items, such as:
Keys, Coins, Pencils, Pens, etc...**

**The delivery address is not parallel to the
longest side of the mailpiece**

**Has clasps, strings, buttons, or similar closure
devices**

Enclosed in plastic material

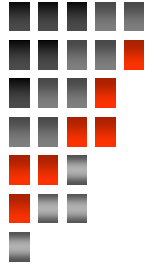

Odd-Shaped Items – Letters & Flats

- **Contains items such as pens, pencils, or loose keys or coins that cause the thickness of the mailpiece to be uneven**

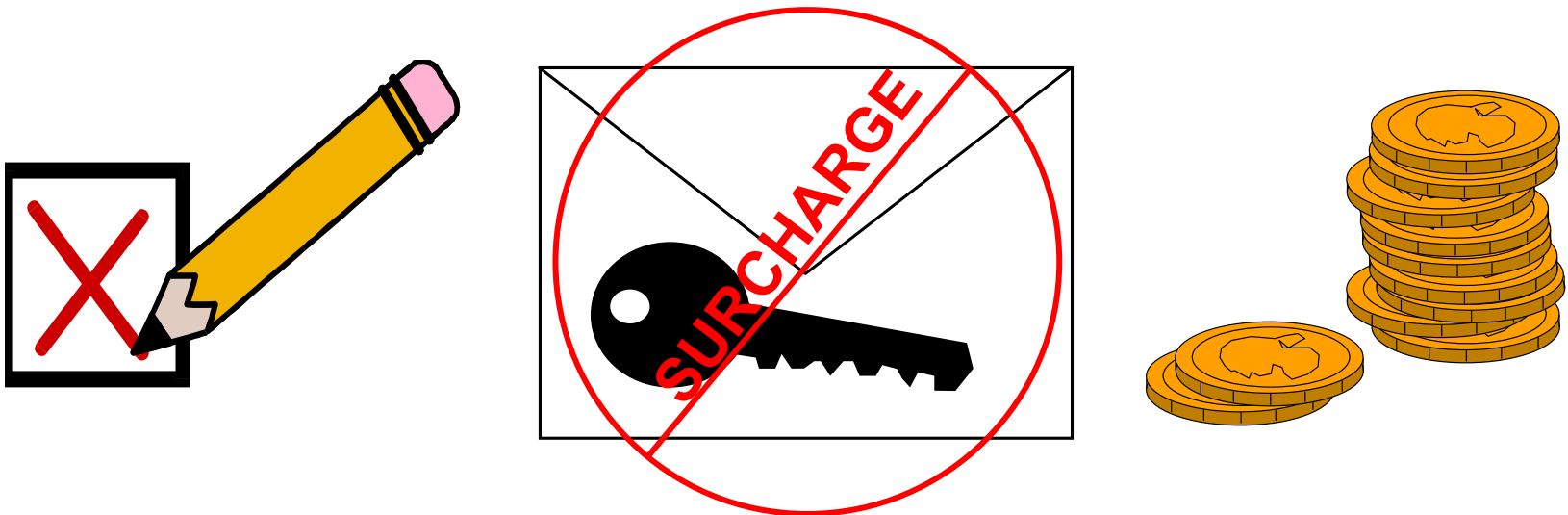

- **Also not permitted on automation-rate letter-size or flat-size mail**

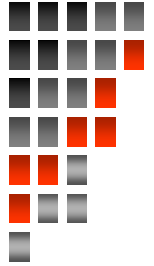

Closure Devices – Letters Only!

Has claps, strings, buttons, or similar closure devices

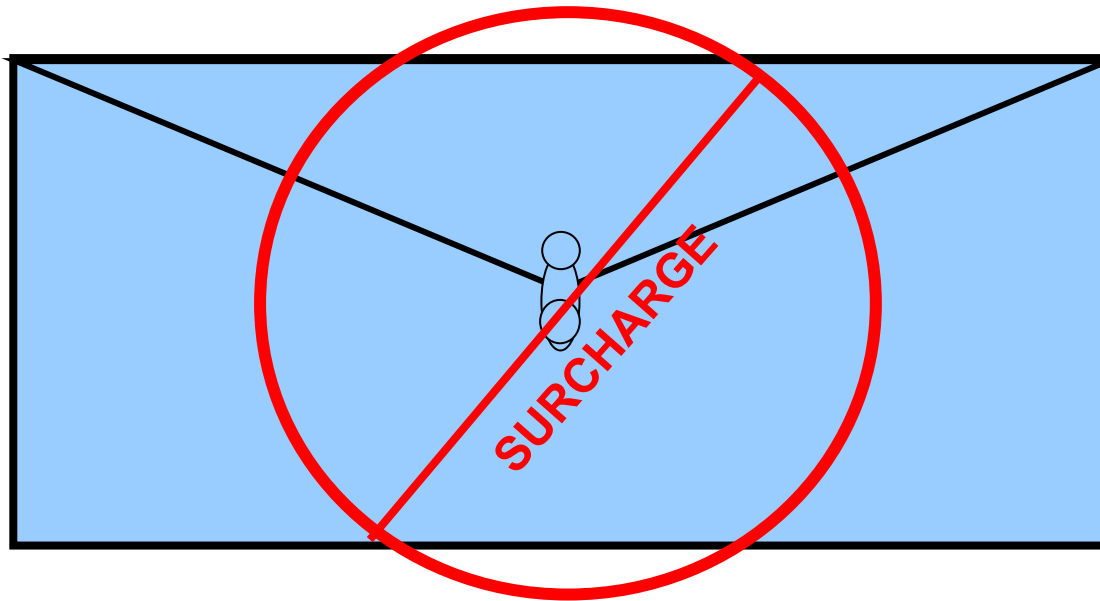

Also not permitted on automation-rate letter-size mail.

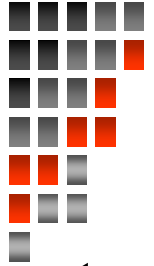

Aspect Ratio – Letters Only

- Aspect ratio (length divided by height) does not meet spec if less than 1.3 or greater than 2.5

Non-machinable
 $4'' \times 5'' = 1.25$

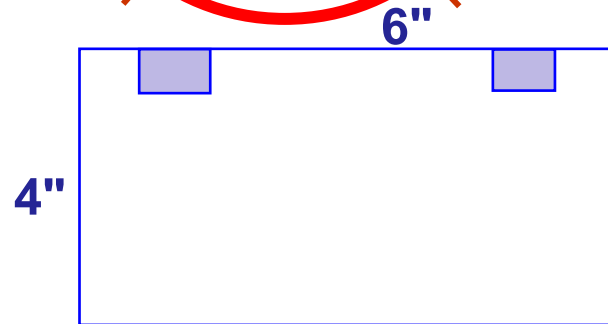
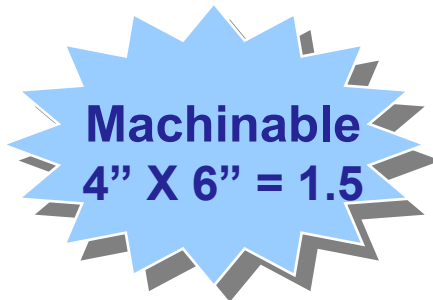
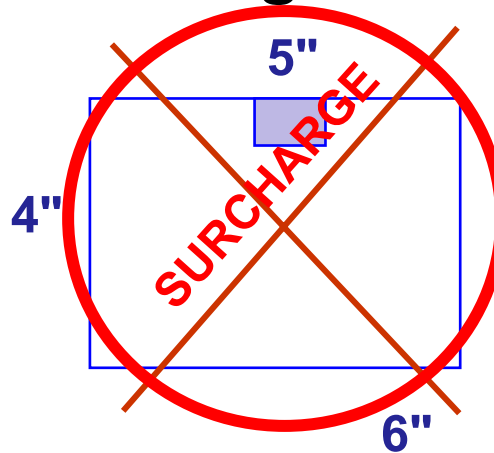

- Also applicable for automation or Qualified Business Reply Mail rates

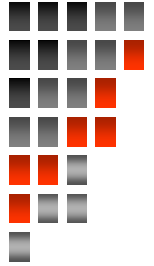

Plastic Covers – Not for Letters!

- Is polybagged, polywrapped, or enclosed in any plastic material OK?

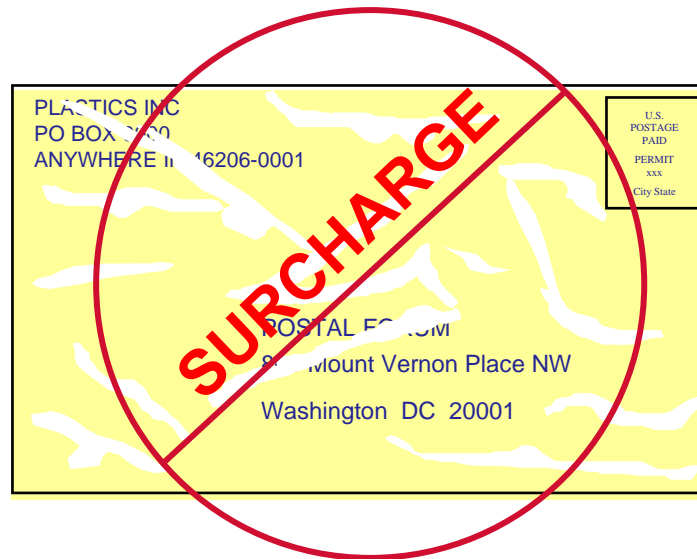

Don't even think about it!!

- Also not permitted on automation-rate size mail

letter-

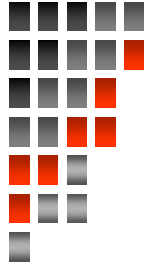

Automating Your Mailpieces Flexibility

Letters

- **Is too rigid (does not bend easily when subjected to a transport belt tension of 40 pounds around an 11-inch diameter turn)**

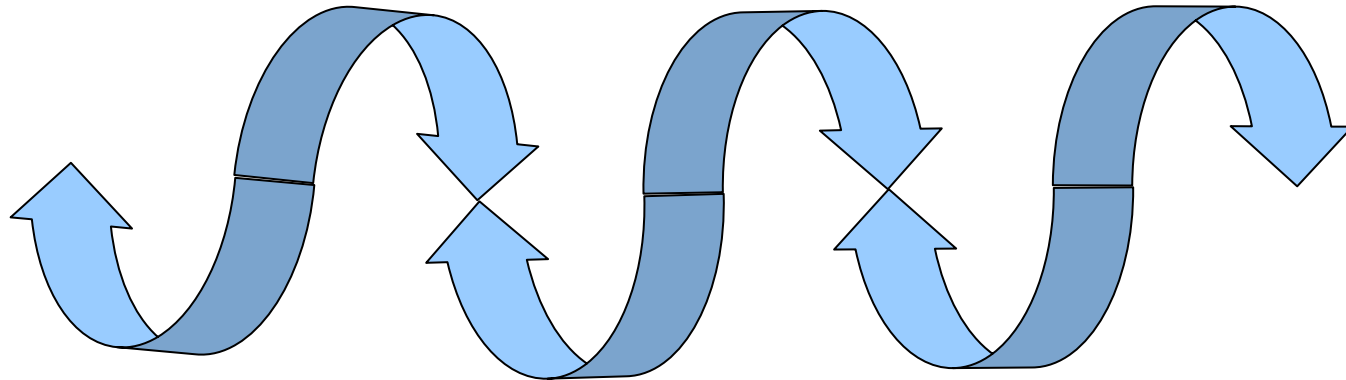

- **Automation-rate letter-size mail must be flexible**

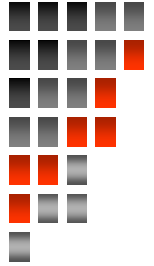

Flats and Large Envelopes

Nonmachinable Large Envelopes

Large envelopes with the following characteristics are subject to package prices:

Not flexible (Rigid)

Not rectangular (Squares are considered rectangular)

Not uniform in thickness (1/4" variation in thickness allowed)

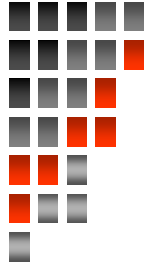

Pricing by Shape

Did You Know:

A large envelope that meets the measurement and weight criteria but is determined to be nonmachinable, will be priced as a package.

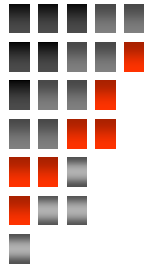

Mailpiece Quality - Reflectance

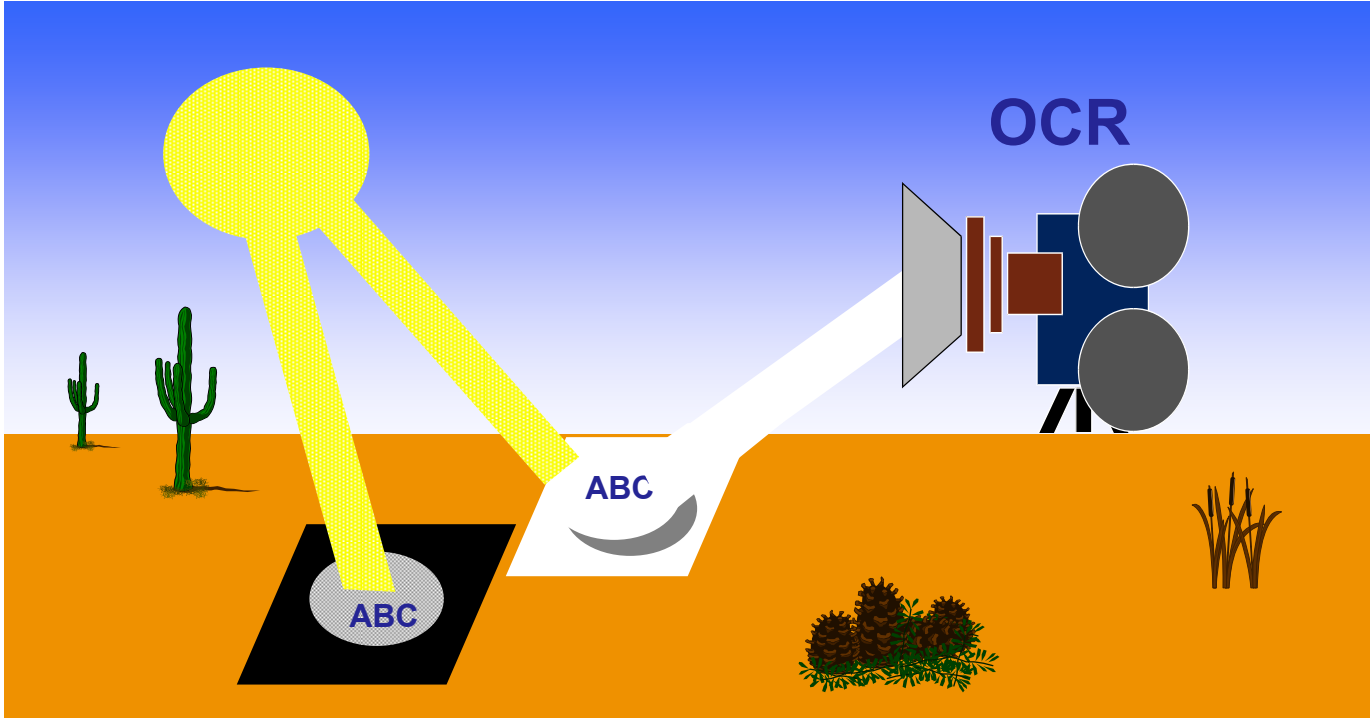

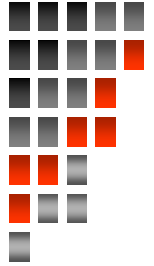

Mailpiece Quality - Print Contrast

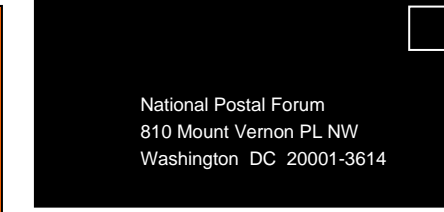
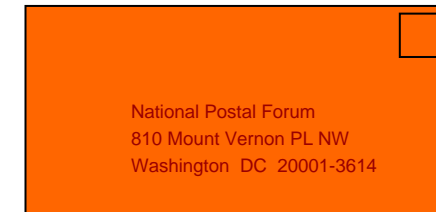
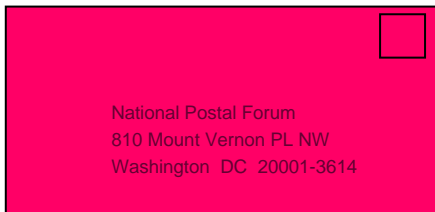
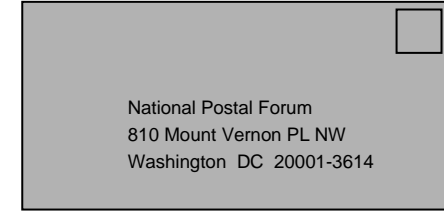
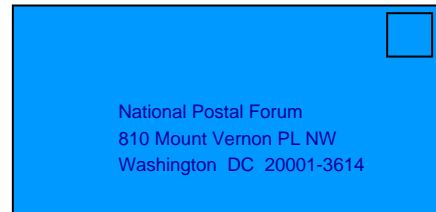
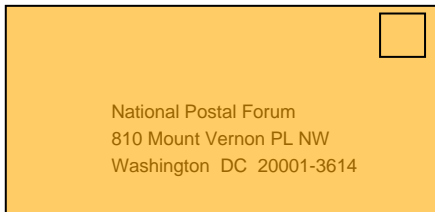
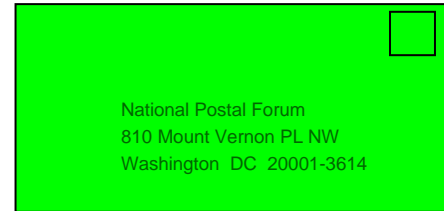
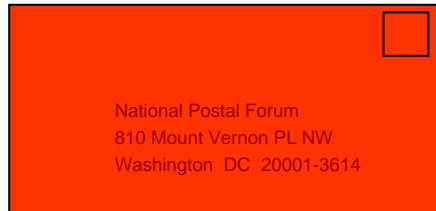
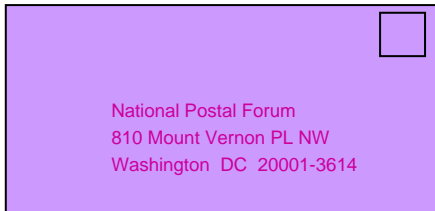



Mailpiece Quality - Choose the Right Colors – Letters & Flats

- **White paper/black ink is BEST!**
- **Pastel colors with dark ink work**

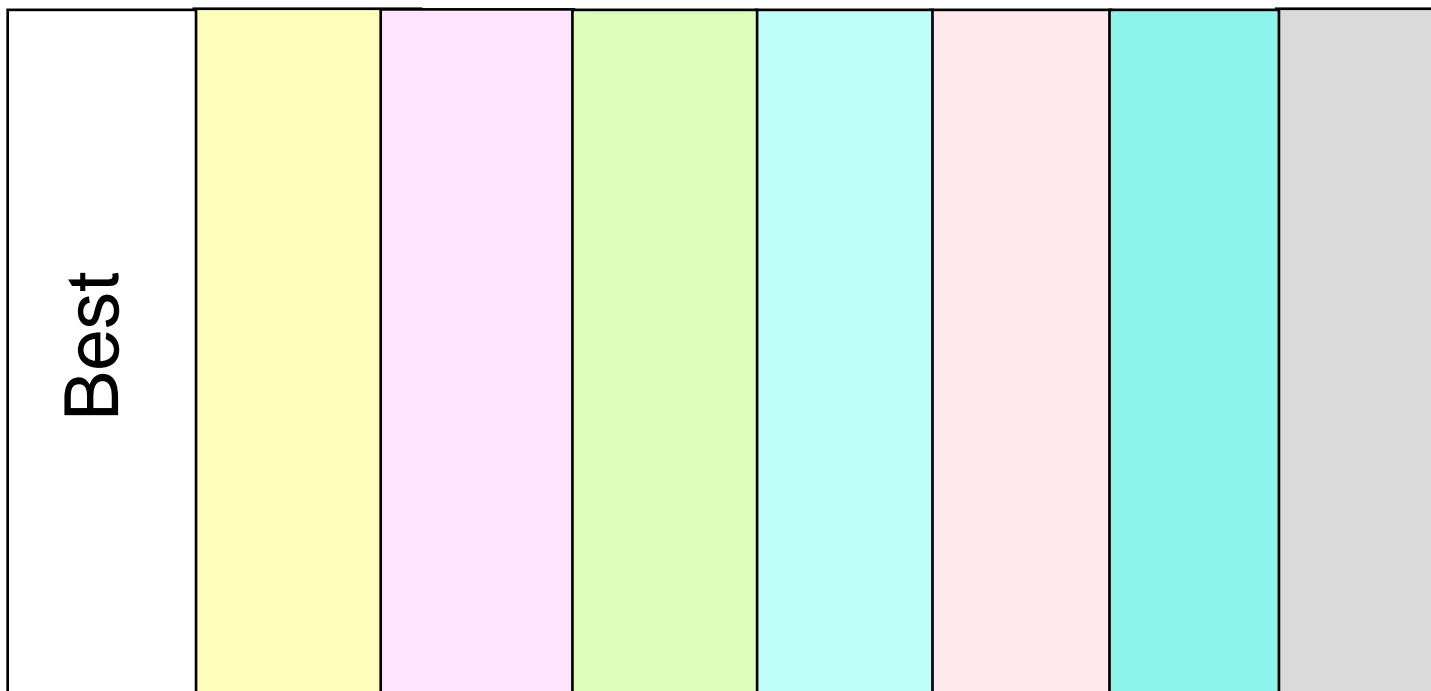

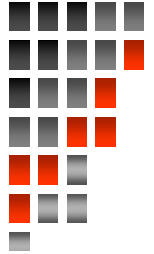

Quality “Not-to-do’s” Incompatible Materials

- Textured/Glossy Paper
- Metallic Paper
- Fluorescence/
Phosphorescence
- Some Recycled Paper
Dark Fibers
- Security Patterns
- 15% Maximum Contrast
- Opacity



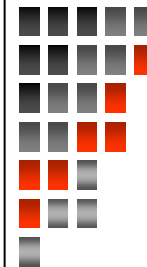

Common Automation Problems

Security Paper

Bleed Through

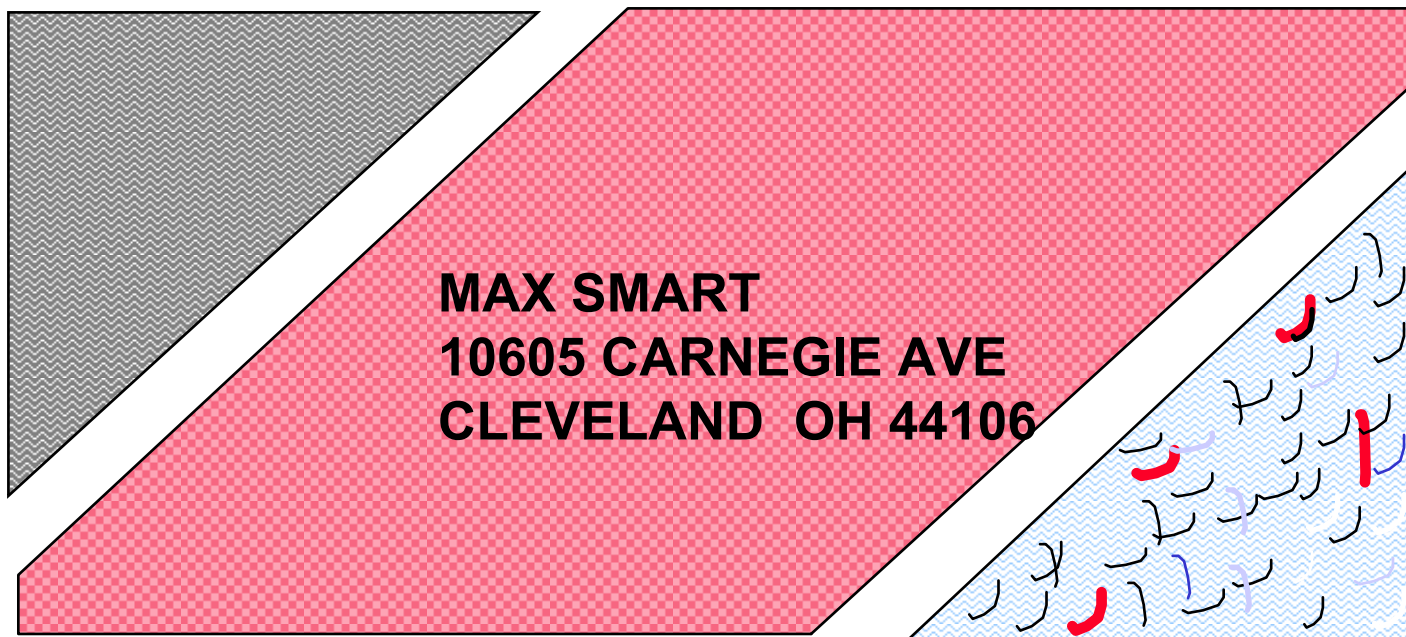

Dark Fibers

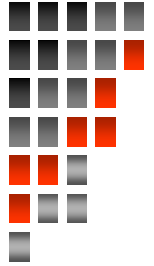

Building Quality – Letters & Flats Address Orientation

- **Has a delivery address parallel to the shorter dimension of the mailpiece**

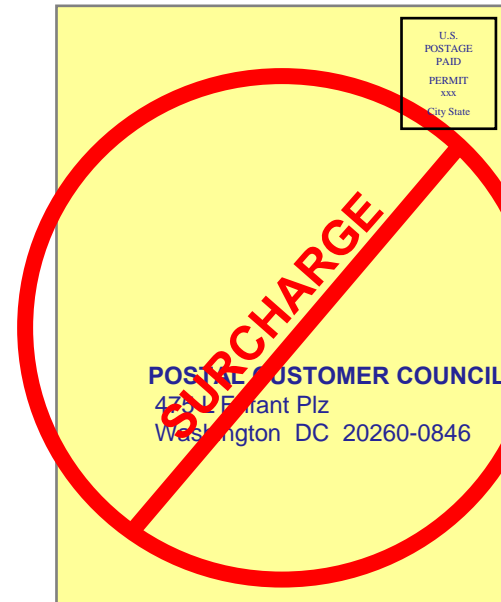

- **Automation rates require that the delivery address be parallel to the longest dimension**



Automating Your Mailpieces Window Envelopes - Letters

Window envelopes must have 1/8" clearance between the address printing and any window edge throughout maximum insert shift

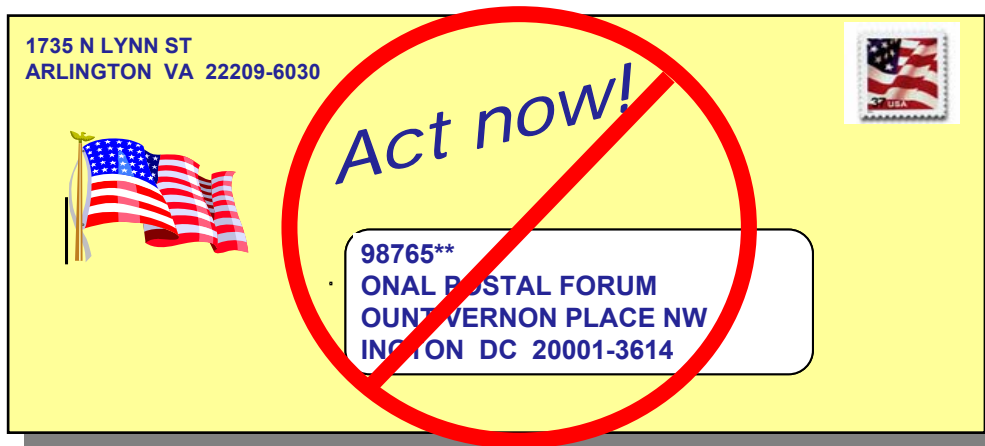
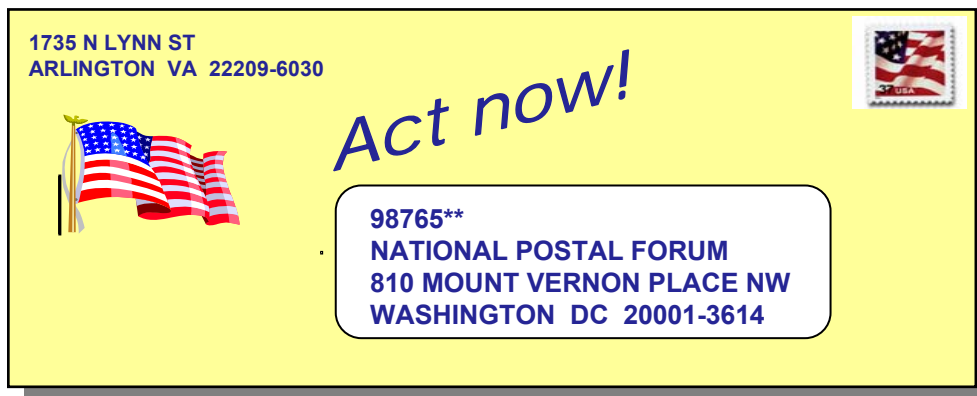



Quality Mailpieces Barcode Placement - Letters

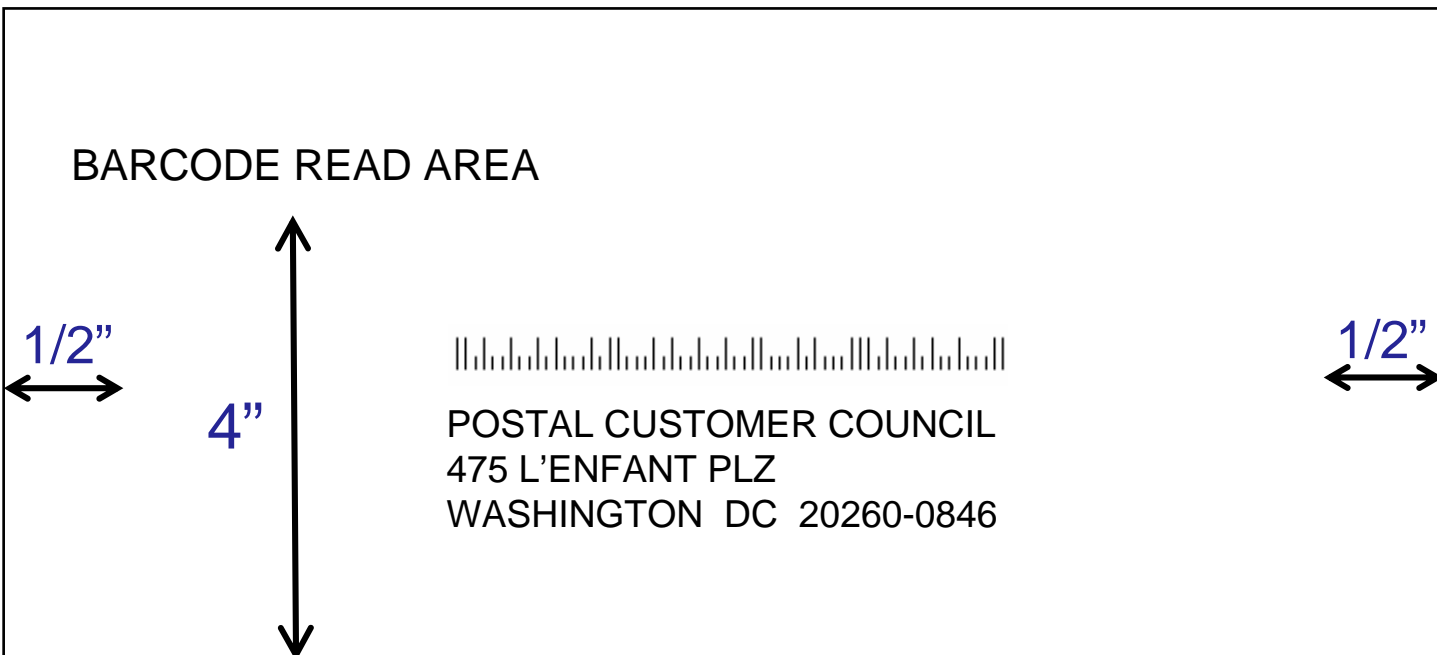

Barcode must be within 4" of mailpiece bottom and at least 1/2" from right or left edge

Entire address block and barcode must be at least 5/8" from bottom

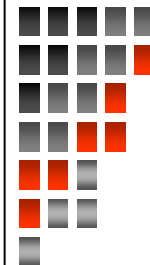

Barcode Clear Zone - Letters

Barcode was in 5/8" area –
and not in Barcode Clear
Zone

FIRST CLASS
PRESORTED
U.S. Postage

you'll enjoy for years to come!

4422008 000100530 25110
JANUARY 25, 2002

#BWNCDTX
#208800932377#

Pleasanton, CA 94566-7754



00001 000

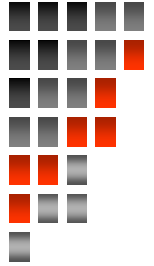

New from the USPS

- **Customized *MarketMail*** – your mailpiece no longer needs to be a square or rectangle, any size or shape can now be mailed*.

*Specific rules and regulations apply to these mailpieces.

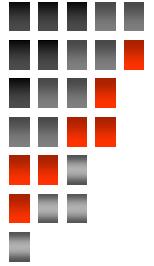

Customized *MarketMail*

A Creative Tool for Advertisers & Marketers

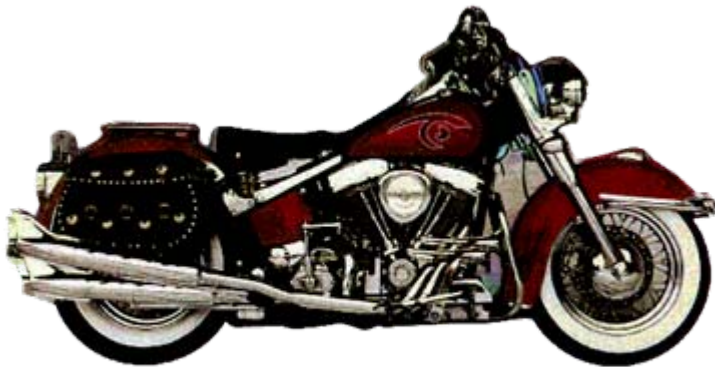

High-Impact Design



Relevant Offer

Innovative Customized *MarketMail* pieces help advertisers and direct marketers break through the *mailbox clutter* and enhance response rates

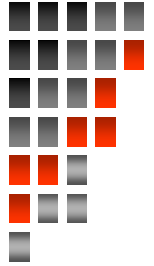

Customized *MarketMail*

Maximum Creative Flexibility

- **Customized *MarketMail* provides generous size and weight options**
 - **Height:** 3 ½" to 12"
 - **Length:** 5" to 15"
 - **Thickness:** 0.007" to 3/4"
Non-uniform thickness
Voids and holes within piece
 - **Weight:** May not exceed 3.3 ounces

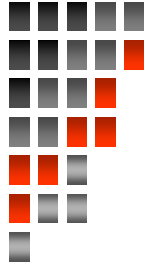

Customized *MarketMail*

So What's the Catch?

- **CMM pieces must be flexible enough to allow placement in smaller mailboxes**
- **A CMM mailing must contain a minimum of 200 pieces**
- **CMM pieces must be delivered to the Postal Service's Delivery Unit's by the customer**
- **There is no forwarding or "Return to Sender" for undeliverable as addressed CMM pieces; undeliverable pieces will be discarded**
- **"Current Resident" or "Occupant Addressee" endorsement required on all CMM pieces**

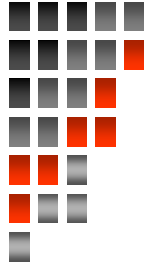

Build Quality Mailpieces Every Time!!



Questions?

Anthony Brunetti
Mail Services Supervisor
Mail Services WT.143
392-35826/25268
Brunettia1@southernct.edu

Richard J. Fabish
Coordinator Duplicating & Mail
Services
Duplicating EN: B012-C
392-5266/25267
Fabishr1@southernct.edu