

Individual Round — Arithmetic

- (1) How many positive divisors (factors) does 24 have?
-

There are 8. (1, 2, 3, 4, 6, 8, 12 and 24 itself)

- (2) A dress whose original price is \$160 is on sale at 25% off. Eileen can also apply her 10% employee discount to further reduce the sale price. How much will she pay?
-

The final price she will pay is \$108.00. The original sale price is \$120.00 and her employee discount gets her 10% or \$12.00 off of *that* amount.

- (3) What is the value of the following alternating sum?

$$1 - 2 + 3 - 4 + 5 - 6 + \dots - 2006 + 2007 - 2008$$

The total is -1004. Group the sum into pairs of terms (like $1 - 2$ and $3 - 4$ and $2007 - 2008$) there are 1004 such pairs and each pair contributes -1 to the sum.

- (4) Consider the following sequence of numbers.

$$3, 7, 13, 21, 31, 43, 57, \dots$$

- a) What is the next term in the sequence?

Notice that the difference between consecutive terms are even numbers. The next term should be 73, which is 14 greater than 57.

- b) Find a general formula for the n th term of the sequence.

Just use “trial and error.” The formula could be $(n + 1)^2 - n$ or $n^2 + n + 1$.

Individual Round — Algebra

- (1) Find a value for x that satisfies the equation $x + 12 = 7 - 2x$.
-

The equation reduces to $3x = -5$ so the solution is $x = -5/3$.

- (2) Find both values of x that satisfy $\frac{10}{x} = x + 3$.
-

Multiply both sides of the equation by x to clear the fraction: $10 = x^2 + 3x$. Then move everything to one side to obtain $x^2 + 3x - 10 = 0$. Finally, factor this as $(x - 2)(x + 5) = 0$ and note the solutions are $x = 2$ and $x = -5$.

- (3) Wesley's father and mother are the same age. Wesley is 23 years younger than they are. The sum of the ages of all three members of the family is 115. How old is Wesley?
-

If we call Wesley's parent's age(s) x and his age y , we get two equations: $2x + y = 115$ and $x - y = 23$. Solving the system of equations leads to $x = 46$ and $y = 23$. So Wesley is 23.

- (4) Suppose that n is a real number greater than 1, and $\sqrt[3]{n\sqrt[3]{n\sqrt[3]{n}}} = n^k$. Find k .
-

We start with n to the first power. Each cuberoot multiplies the exponent by $1/3$ and each further product of n increases the exponent by 1, so we get $((((1 \cdot 1/3) + 1) \cdot 1/3) + 1) \cdot 1/3$. Tallying all this up gives $k = 13/27$.

Individual Round — Geometry

- (1) Recall that the formula for the area of a circle is $A = \pi R^2$, where R is the radius of the circle. What is the area of a circle whose *diameter* is 10?
-

The circle's radius is 5. The area is $\pi \cdot 5^2$ or 25π . A decimal approximation is 78.54

- (2) If a square has an area of 144 square inches, what is its perimeter?
-

The square must be 12 by 12 to have an area of 144 square inches. Its perimeter is 4 times its side length: 48 inches.

- (3) What is the distance between diagonally opposite corners of a $1 \times 1 \times 1$ cube?
-

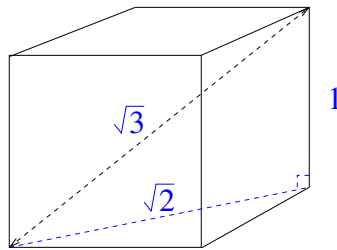

The diagonal of any *face* of the cube is $\sqrt{2}$. There is a right triangle that one can construct in the interior of the cube having sides $\sqrt{2}$ and 1. The hypotenuse of this triangle is the desired value, which is $\sqrt{3}$ by the Pythagorean theorem.

- (4) A goat is tethered to the corner of a barn with a rope that is 100 feet long. If the barn is 50 feet by 50 feet square (as seen from above), what is the area of the region that the goat can graze in?
-

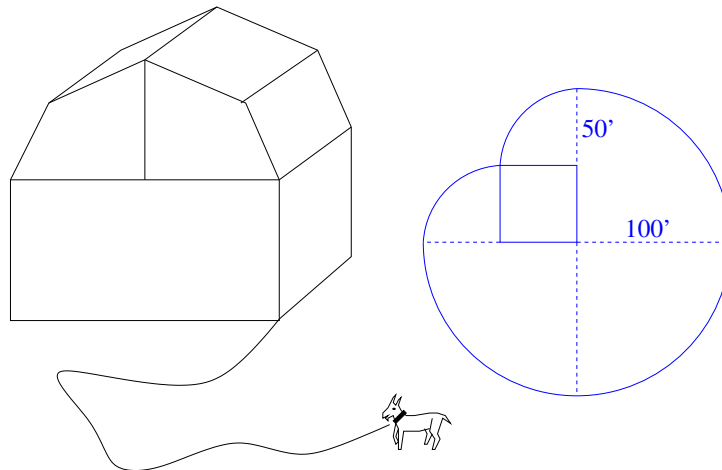

The region the goat can graze in can be dissected into 5 pieces that are sectors (quarters) of circles. The total area is $8750 \cdot \pi$ or approximately 27,489 square feet.

Team Round — CAPT

Estimate the following quantities. Use feet, square feet, and/or cubic feet (as appropriate) for units.

- (1) The height of the sundial outside the main entrance of Engleman Hall.
(The sundial is in the form of a giant half-cylinder.)
-

About 46 feet.

- (2) The total area of the five banners on the front of Buley Library that spell SCSU.
-

Each banner is 12 feet wide and 16 feet high. The total area is 960 square feet.

- (3) The volume of the circular planter in the center of the quad.
-

The planter is a cylinder approximately 2 feet high and 28 feet in diameter. The volume of a cylinder is its height times the area of its base ($V = h \cdot \pi r^2$) which leads us to approximately 1230 cubic feet.

Team Round — General

- (1) Find the dimensions of the slanted rectangle. (Both of the squares are 1 unit on a side.)

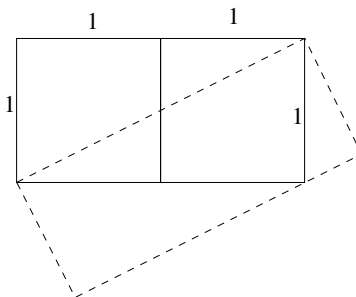

The long dimension of the rectangle is $\sqrt{5}$ by the Pythagorean theorem. The other dimension can be discovered by considering similar triangles. It is $2/\sqrt{5}$. Thus the total area is 2.

- (2) In a circle of radius 2, two radii are drawn from the center to the endpoints of a chord of length $2\sqrt{3}$. Find the shaded area.

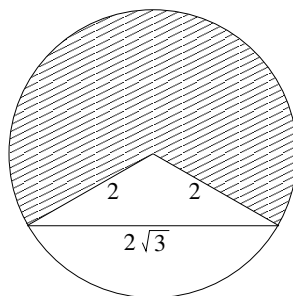

The angle at the center of the circle that defines the unshaded region can be deduced to be 120° , so the area of the shaded region is two-thirds of the area of the full circle. Thus, $A = \frac{2}{3}\pi 2^2$ or $\frac{8}{3}\pi$ or approximately 8.38.

- (3) What is the sum of the first 2008 odd numbers?

$2008^2 = 4032064$. Just try this for small examples until you see the pattern...

$$1 = 1 \quad 1 + 3 = 4 \quad 1 + 3 + 5 = 9 \quad 1 + 3 + 5 + 7 = 16$$

et cetera.

(4) How many (decimal) digits does 2^{2008} have?

2^{2008} causes an overflow on your calculator, but 2^{1004} . . . still causes an overflow. Keep dividing the exponent by two and eventually you find that 2^{251} can be computed and (in scientific notation) it is $3.618502789 \times 10^{75}$. From this you can find 2^{2008} by raising it to the eight power by hand.

$$(3.618502789 \times 10^{75})^8 = 29392.14 \times 10^{600}$$

So there are 605 digits in this gigantic number!

NEW HAVEN HIGH SCHOOL MATHEMATICS COMPETITION – 2008